



System and Network
Engineering

Towards energy efficient data intensive computing using IEEE 802.3az

*Dimitar Pavlov, Joris Soeurt, Paola Grosso, **Zhiming Zhao**,
Karel van der Veldt, Hao Zhu, Cees de Laat*

System and Network Engineering Group



UNIVERSITEIT VAN AMSTERDAM



Network energy saving in distributed computing systems

- Available approaches in Energy Efficient Ethernet
 - Power down unused switch ports
 - Adjust the cable length
 - Turn inactive ports to sleep when no traffic

The 802.3az protocol

- Control port status based on network traffic
- Final standard released in 9/2010
- Products available later 2011



S1728GWR-4P



1) Huawei S1728GWR-4P 2) Cisco SG300-28

Motivation

- Can we make use of 802.3az in optimizing the energy efficiency of an application in cluster environments?

Contents

- How does IEEE802.3az work?
- How to use IEEE 802.3az?
 - Energy behavior of IEEE 802.3az in practice
 - Proposed system
- Experimental study
- Conclusions
- Future work

Basic idea of IEEE 802.3az

- The IEEE 802.3az protocol turns inactive links to a low power model based on the traffic condition on those links; it refreshes in a interval to detect coming traffic and wakes up.

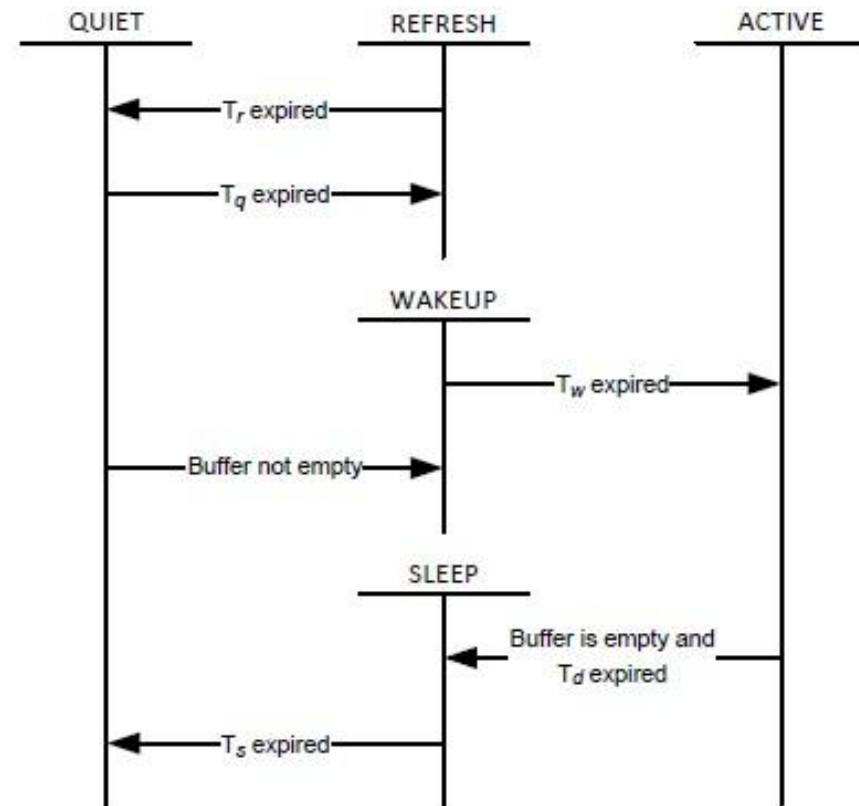
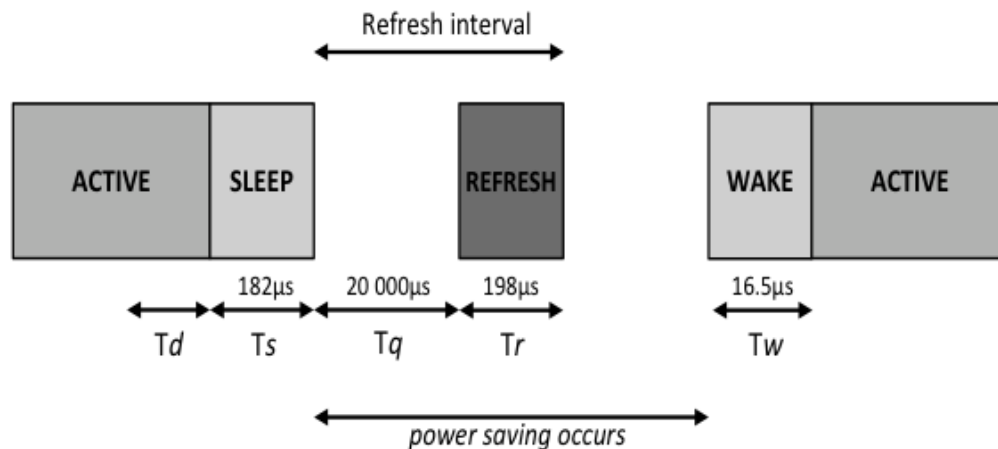

Our approach

- Profile the energy behavior of IEEE 802.3az devices
 - Dependencies on communication patterns
 - Check the difference between simulation study [1] and actual implementations
- Estimate the energy consumption for an application in a specific network
 - Schedule applications based on the communication patterns

[1] P. Reviriego, J.A. Hernandez, D. Larrabeiti, and J.A. Maestro. Performance Evaluation of Energy Efficient Ethernet. 2009.

Experiment setup

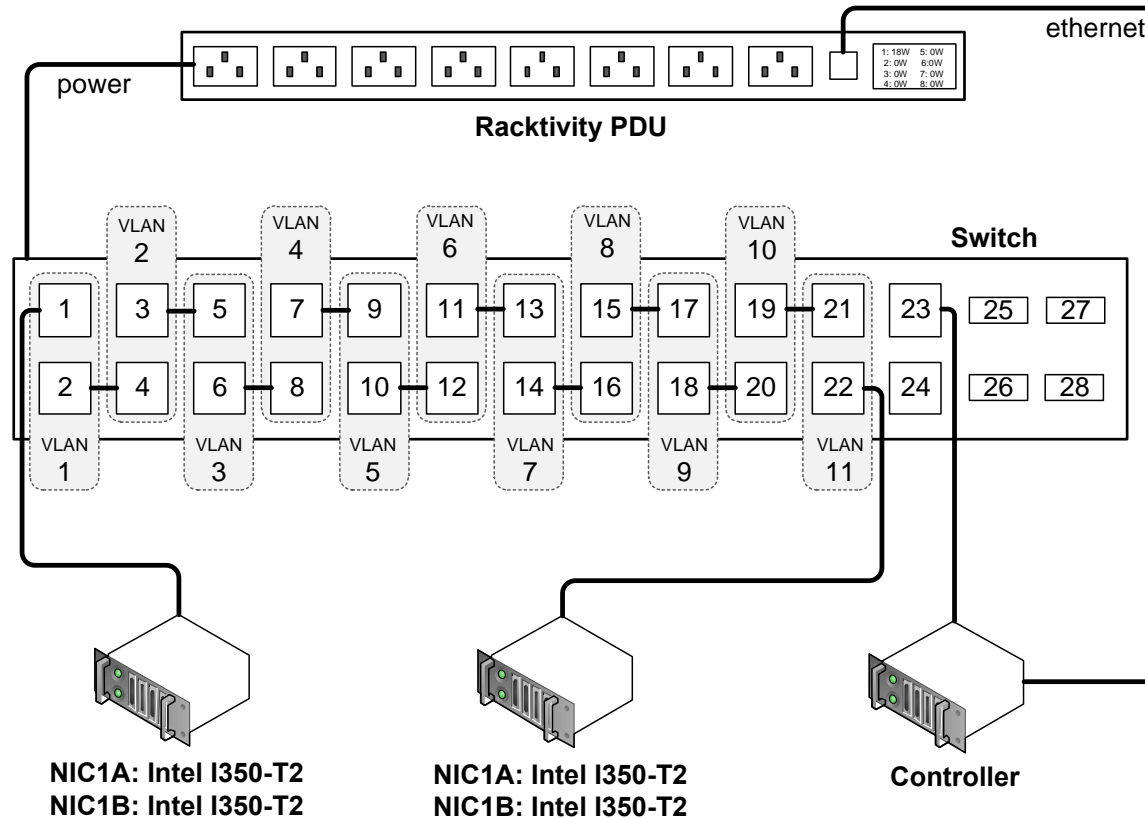

Two devices tried:
Huawei S1728GWR-4P vs. Cisco SG300-28
PDU: Rackactivity ES6024-16

Max and Min energy consumption

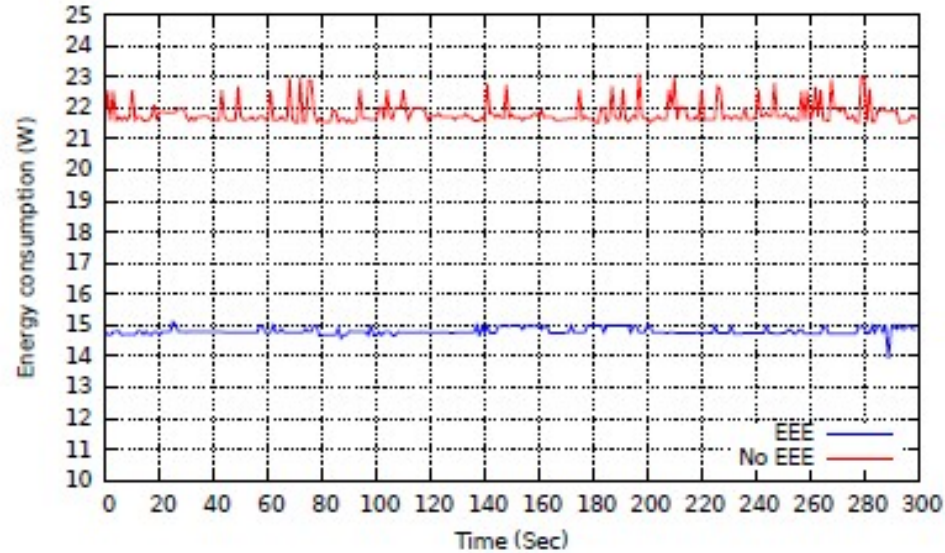

A) Huawei (37% saving)

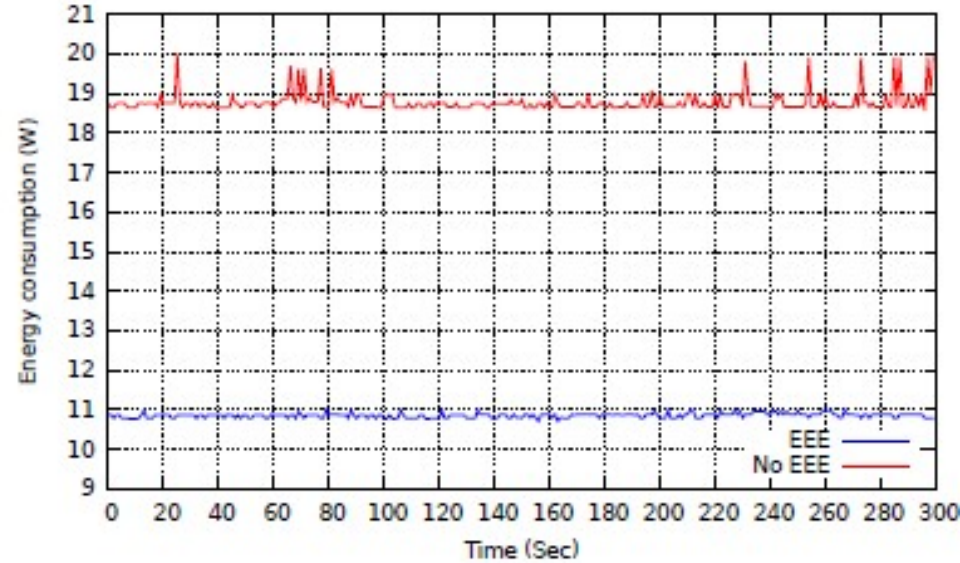

B) Cisco (40% saving)

Energy vs. Throughput (1000BASE-T)

Huawei

Cisco

TCP

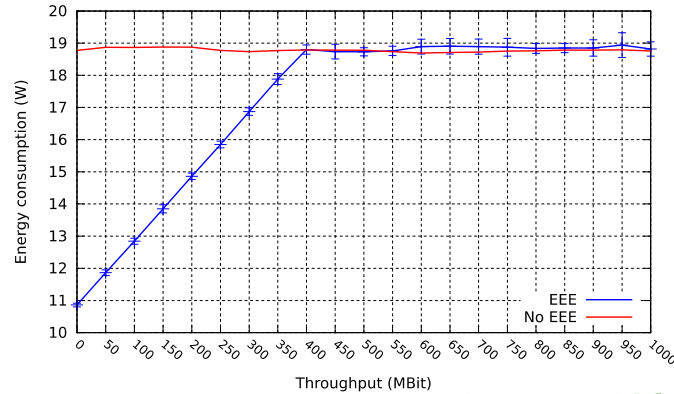
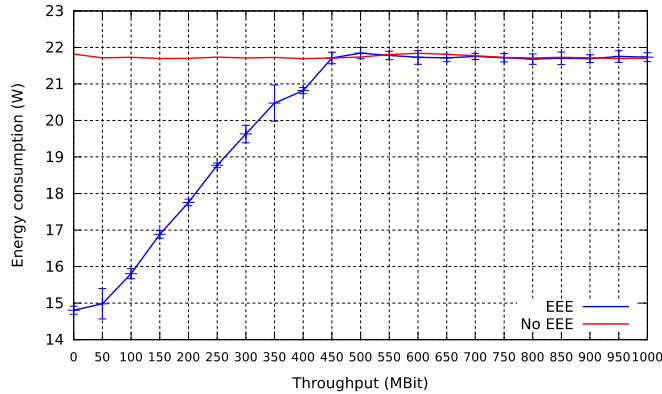

Both EEEs show a linear increase in power consumption

UDP

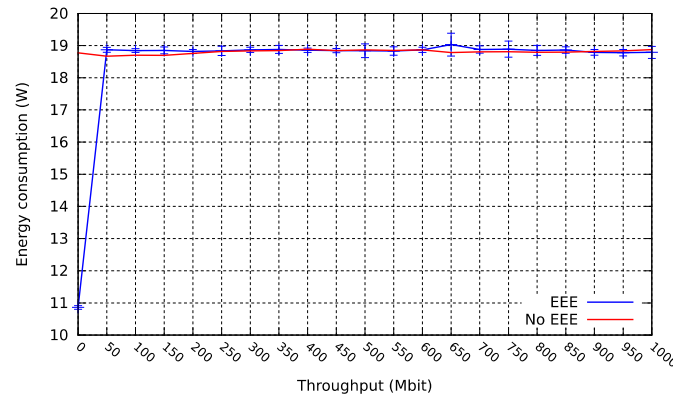
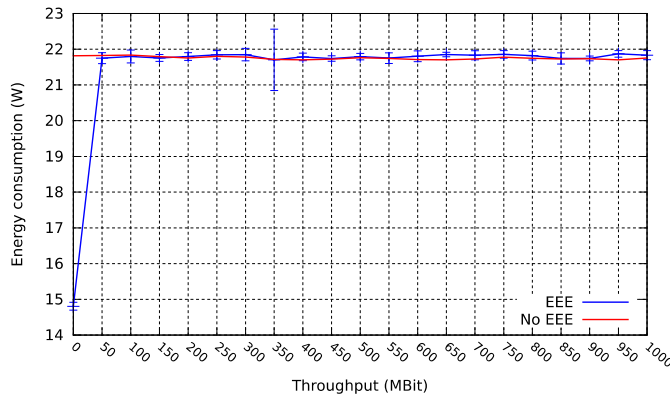

Both EEEs always consume maximum energy, regardless of throughput.



Energy vs. Inter-frame delay(TCP, 1000BASE-T)

Huawei

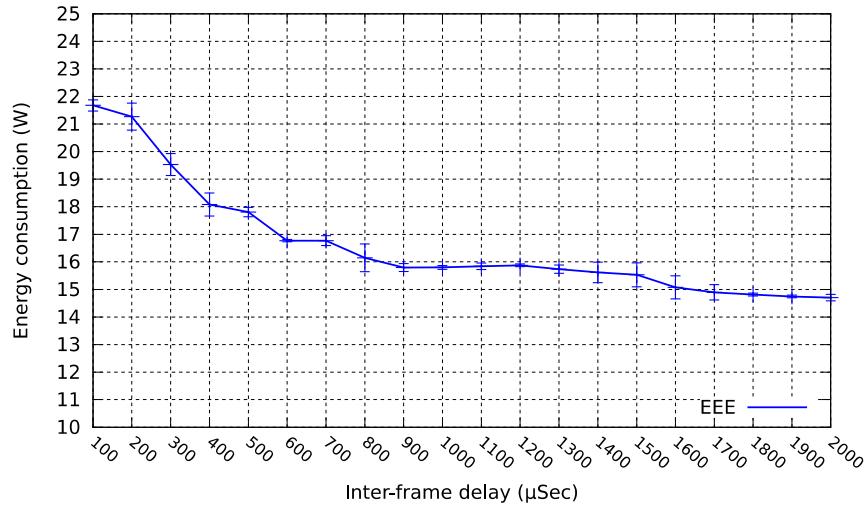

Cisco

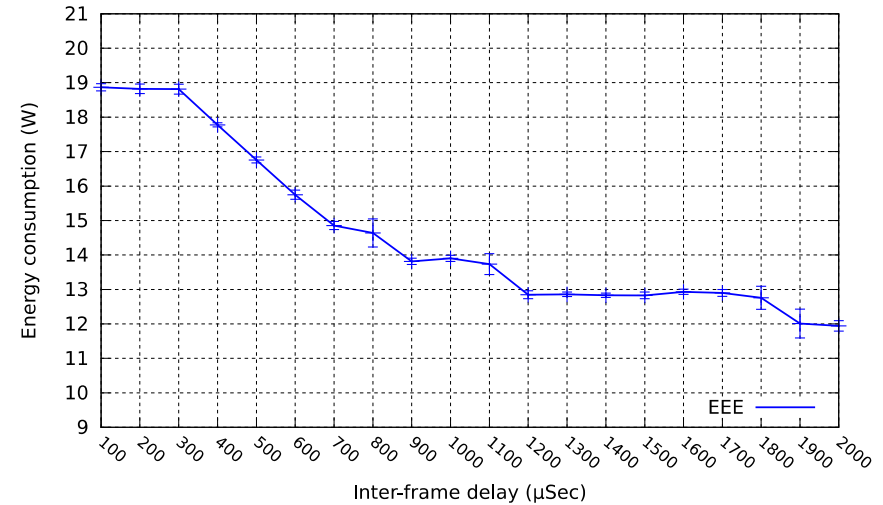

The Huawei device starts saving energy at smaller inter-frame delay values than the Cisco device.

What did we learn?

- 802.3az is effective in reducing the energy consumption of TCP traffic. The amount of energy saved varies depending on vendor.
- The inter-frame time interval influences the energy consumption of running the data intensive application.
- Energy saving :
 - Set a suitable and stable interval.
 - Buffer application requests to increase idle time.

Cont.

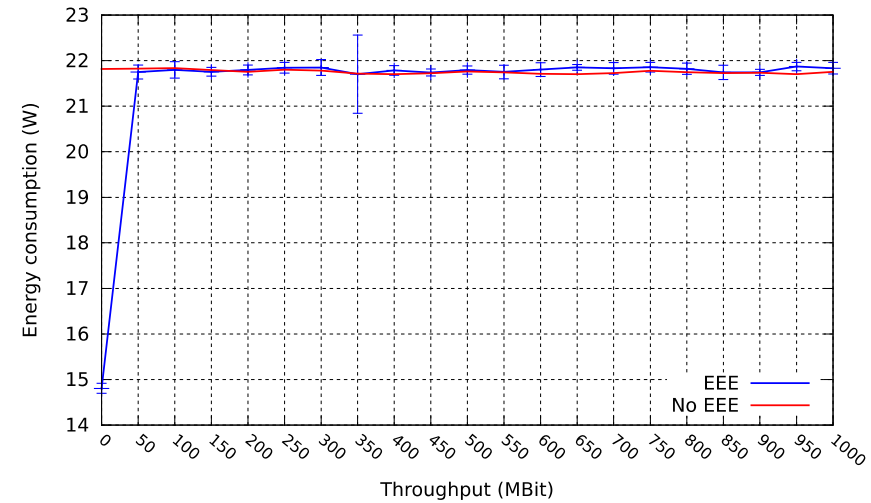
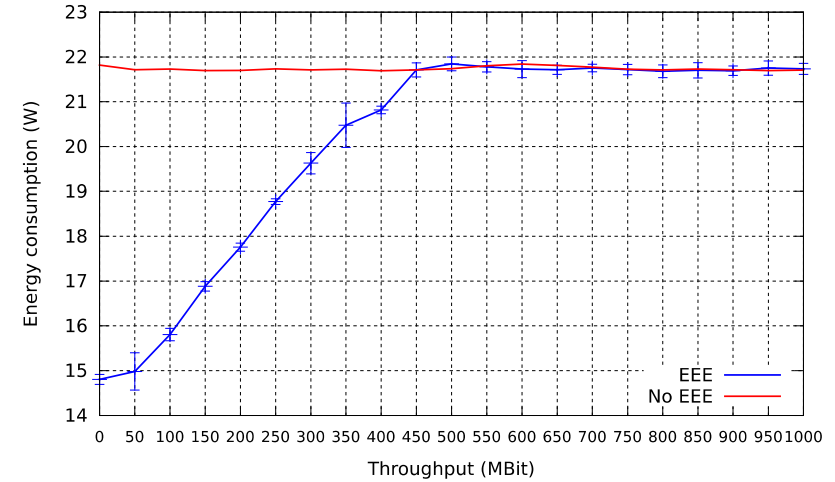
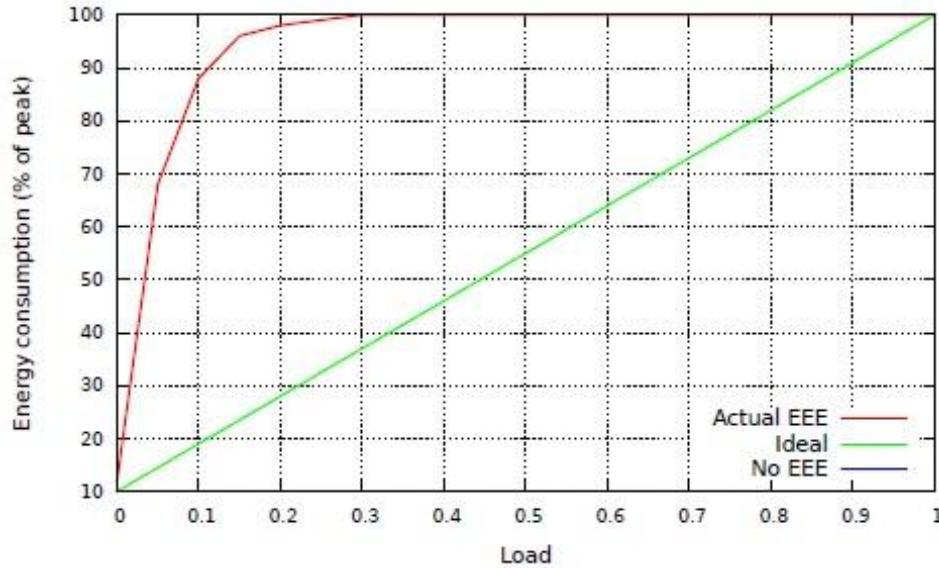

Simulation made in [1]

[1] P. Reviriego, J.A. Hernandez, D. Larrabeiti, and J.A. Maestro. Performance Evaluation of Energy Efficient Ethernet. 2009.

Power Budget Calculator

- The goal of modeling is to:
 - Estimate the energy consumption generated by the data transmission.
 - Understand the impact of changes to the scenarios: e.g. adding new nodes.
 - Optimize based on scenario: e.g. determine best number of used nodes or reduce the transmission speed.
- The model derives from parameters of data-intensive tasks and the energy profiling in the EEE environment.
- Components: Task-based Estimate and Data-based Estimate.

Use cases of the Calculator

Optimize the scenarios: calculate the energy usage in different conditions and determine optimal execution parameters

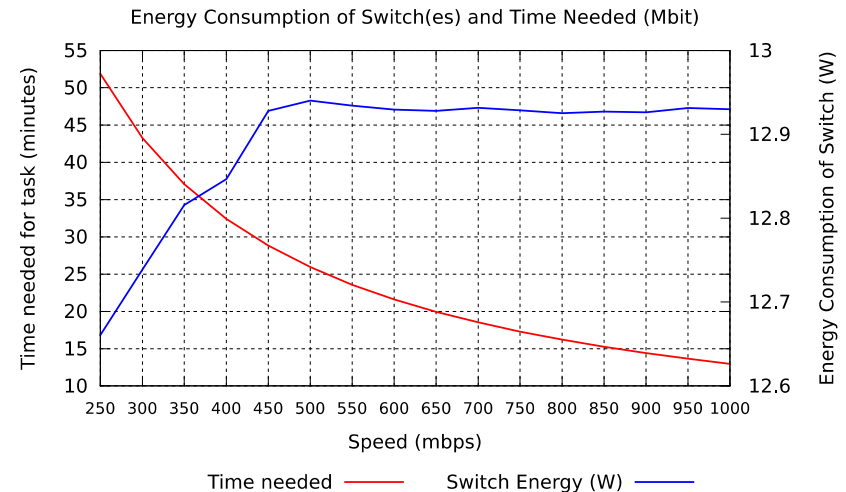
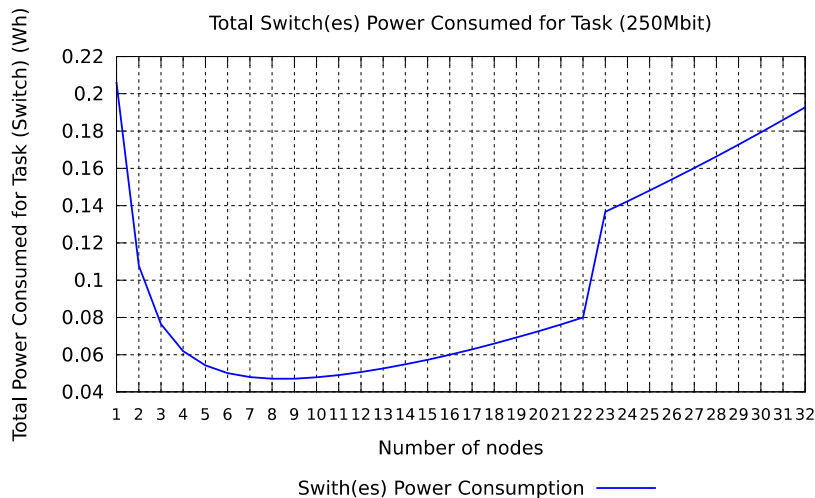

$$\text{Energy} = ((P_{tp} - P_b) / N_p) * N * ((T_s / n) + (n - 1) * C). \quad \text{Energy} = ((P_{tp} - P_b) / N_p) * N * (D_{size} / \text{Throughput})$$

Conclusions

- 802.3az is effective in reducing the energy consumption of device.
 - The amount of energy saved varies depending on vendor.
- Power Budget Calculator
 - An energy model of transmission in network.
 - Applied to energy optimization.

Future work

- The future version of the Calculator will be free of unrealistic assumptions and incorporated into our scheduler.
- The Calculator will be included in the ongoing energy knowledge base system, which exposes measurement data and supports prediction of energy characteristics.

Reference

- Acknowledgement



- URL of Power Budget Calculator
 - <https://github.com/zupper/cluster-efficiency>